

**KEITHLEY**

---

**Model 195T  
System Temperature DMM  
Instruction Manual Supplement**

**Document Number: 195T-901-01A  
Publication Date: February 1983**

## WARRANTY

We warrant each of our products to be free from defects in material and workmanship. Our obligation under this warranty is to repair or replace any instrument or part thereof which, within a year after shipment, proves defective upon examination. We will pay local domestic surface freight costs.

To exercise this warranty, write or call your local Keithley representative, or contact Keithley headquarters in Cleveland, Ohio. You will be given prompt assistance and shipping instructions.

## REPAIRS AND CALIBRATION

Keithley Instruments maintains a complete repair and calibration service as well as a standards laboratory in Cleveland, Ohio.

A Keithley service facility at our Munich, Germany office is available for our customers throughout Europe. Service in the United Kingdom can be handled at our office in Reading. Additionally, Keithley representatives in most countries maintain service and calibration facilities.

To insure prompt repair or recalibration service, please contact your local field representative or Keithley headquarters directly before returning the instrument. Estimates for repairs, normal recalibrations and calibrations traceable to the National Bureau of Standards are available upon request.

# KEITHLEY

**Keithley Instruments, Inc./28775 Aurora Road/Cleveland, Ohio 44139/U.S.A./(216) 248-0400/Telex: 98-5469**

**WEST GERMANY: Keithley Instruments GmbH/Heiglhofstrasse 5/D-8000 München 70/(089) 714-40-65/Telex: 521 21 60**

**GREAT BRITAIN: Keithley Instruments, Ltd./1, Boulton Road/Reading, Berkshire RG2 ONL/(0734) 86 12 87/Telex: 847047**

**FRANCE: Keithley Instruments SARL/2 Bis, Rue Léon Blum/B.P. 60/91121 Palaiseau Cedex/(6) 011.51.55/Telex: 600933F**

**NETHERLANDS: Keithley Instruments BV/Arkelsedijk 4/NL-4206 AC Gorinchem/(01830) 25577/Telex: 24 684**

**SWITZERLAND: Keithley Instruments SA/Kriesbachstr. 4/CH-8600 Dübendorf/01 821 94 44/Telex: 57 536**

**AUSTRIA: Keithley Instruments Ges.m.b.H./Döblinger Hauptstr. 32/A-1190 Wien/0222 314 289/Telex: 13 45 00**

**Model 195T  
System Temperature DMM  
Instruction Manual Supplement**

**©1983, Keithley Instruments, Inc.  
Cleveland, Ohio, U.S.A.**

## SPECIFICATIONS

TEMPERATURE (6½ DIGITS)		RESOLUTION	4-WIRE	TEMPERATURE
SPAN			ACCURACY <sup>1</sup>	COEFFICIENT
			± (%rdg + counts) 1 YR., 18°-28°C	± (%rdg + counts)/°C 0°-18°C & 28°-50°C
°C				
-200.00° to 230.00°	0.01°	0.01°	0.03 + 10	0.003 + 0.4
230.00° to 630.00°	0.01°	0.01°	0.03 + 40	0.003 + 4
-220.00° to -200.00°	0.01°	0.01°	0.03 + 40	0.003 + 4
°F				
-328.00° to 446.00°	0.01°	0.01°	0.03 + 18	0.003 + 0.7
446.00° to 1100.00°	0.01°	0.01°	0.03 + 72	0.003 + 7
-360.00° to -328.00°	0.01°	0.01°	0.03 + 72	0.003 + 7

<sup>1</sup>Autorange mode, excluding probe errors.

**RTD TYPE:** 100Ω platinum; DIN 43 760 or IPTS-68, Programmable alpha and delta, 3- or 4-wire.

**MAXIMUM LEAD RESISTANCE (each lead):** 4-wire: 25Ω.  
3-wire: 15Ω.

**SENSOR CURRENT:** 1.0mA maximum, RMS.

**BENCH READING RATE:** 1.2 readings per second.

**MAXIMUM COMMON MODE VOLTAGE:** 500V (42V with Model 1951 connected).

**COMMON MODE REJECTION:** Less than 0.005°C/volt at DC, 50Hz and 60Hz (100Ω unbalance, LO driven).

**MAXIMUM ALLOWABLE INPUT:** 360V peak, 250V rms.

**ACCESSORIES SUPPLIED:** Model 1951 Input Adapter, Model 8693 General Purpose/Immersion Probe (4-wire).

**ACCESSORIES AVAILABLE:**

- Model 1951 Input Adapter
- Model 8691 Connector Kit (enables connecting to 3- or 4-wire RTDs)
- Model 8693 General Purpose/Immersion Probe (4-wire)
- Model 8695 Surface Probe (4-wire)
- Model 8696 Air/Gas Probe (4-wire)

Specifications subject to change without notice.

# TABLE OF CONTENTS

Paragraph	Title	Page
<b>SECTION 1 GENERAL INFORMATION</b>		
1.1	Introduction .....	1-1
1.2	Model 195T Features .....	1-1
1.3	Warranty Information .....	1-1
1.4	Manual Addenda .....	1-1
1.5	Safety Terms and Symbols .....	1-1
1.6	Specifications .....	1-1
1.7	Unpacking and Inspection .....	1-1
1.8	Scope of Model 195T Instruction Manual .....	1-1
1.9	Accessories .....	1-2
1.9.1	Model 195T Input Adapter Box .....	1-2
1.9.2	Model 8691 Connector Kit .....	1-2
1.9.3	Model 8693 General Purpose Immersion Probe .....	1-2
1.9.4	Model 8695 Surface Probe .....	1-2
1.9.5	Model 8696 Air/Gas Probe .....	1-2
<b>SECTION 2 OPERATION</b>		
2.1	Introduction .....	2-1
2.2	Probe Connection .....	2-1
2.3	Temperature Measurement Procedure .....	2-1
2.4	IEEE Bus Control of Temperature Measurements .....	2-2
2.4.1	IEEE Temperature Commands .....	2-2
2.4.2	IEEE Bus Temperature Data Format .....	2-2
2.5	3-Wire Sensor Operation .....	2-3
2.6	Calibration Standards .....	2-3
<b>SECTION 3 PERFORMANCE VERIFICATION</b>		
3.1	Introduction .....	3-1
3.2	Environmental Conditions .....	3-1
3.3	Recommended Equipment .....	3-1
3.4	Initial Conditions .....	3-1
3.5	Verification Procedure .....	3-1
<b>SECTION 4 THEORY OF OPERATION</b>		
4.1	Introduction .....	4-1
4.2	RTD Resistance Measurement .....	4-1
4.3	FET Switching Sequence .....	4-1
4.4	Reading Calculations .....	4-1
<b>SECTION 5 SERVICING INFORMATION</b>		
5.1	Introduction .....	5-1
5.2	Calibration .....	5-1
5.2.1	Environmental Conditions .....	5-1
5.2.2	Warm-Up Period .....	5-1
5.2.3	Calibration Constants .....	5-1
5.2.4	Front Panel Calibration Procedure .....	5-1
5.2.5	Temperature Calibration Over the IEEE-488 Bus .....	5-2
5.3	Replaceable Parts .....	5-2
5.3.1	Ordering Information .....	5-2
5.3.2	Parts List .....	5-3
5.4	Troubleshooting Information .....	5-3
5.5	Component Layouts and Schematics .....	5-3

## LIST OF FIGURES

Figure	Title	Page
2-1	Model 195T Front Panel Showing Model 1951 Input Adapter Box.....	2-1
2-2	Model 195T Probe Wiring .....	2-1
2-3	3-Wire Sensor Connections .....	2-3
3-1	Connections for Performance Verification .....	3-1
4-1	Simplified Circuit of RTD Resistance Measurement .....	4-1
4-2	FET Switching Sequence .....	4-1
4-3	FET Switching Sequence for RTD Resistance Measurements .....	4-2
5-1	Remote Box, Schematic Diagram, Drawing Number 1951-106 .....	5-4
5-2	Mother Board, Component Layout, Drawing Number 195T-100 .....	5-5
5-3	Mother Board, Schematic Diagram, Drawing Number 195T-106 .....	5-9

## LIST OF TABLES

Table	Title	Page
2-1	Calibration Standards .....	2-3
3-1	Performance Verification Summary .....	3-1
5-1	Calibration Procedure Messages .....	5-1
5-2	Model 195T Replaceable Parts List .....	5-3

# SECTION 1

## GENERAL INFORMATION

### 1.1 INTRODUCTION

The Model 195T is an enhanced version of the Model 195 that includes temperature measuring capabilities. The Model 195T is capable of temperature measurements in the range of  $-220^{\circ}\text{C}$  and  $+630^{\circ}\text{C}$  and between  $-360^{\circ}\text{F}$  and  $+1100^{\circ}\text{F}$ . The instrument is designed to work with platinum RTD probes, a factor which contributes to high accuracy. Temperature readings may be read directly from the front panel display or transmitted over the IEEE bus to a central controller or other instrumentation.

### 1.2 MODEL 195T FEATURES

Some key Model 195T features include:

1. **High Accuracy.** Because platinum RTD probes have predictable resistance change with temperature and are highly linear, temperature measurements are made with a greater degree of accuracy than is possible with thermistor or thermocouple type probes.
2. **Ease of Use.** The temperature measuring mode is easily entered from the front panel or over the IEEE bus. Sophisticated software automatically measures the probe resistance and calculates the reading.
3. **Dual Scale Temperature Measurements.** Temperature readout may be obtained in either  $^{\circ}\text{C}$  or  $^{\circ}\text{F}$ . Readings are available on the display and over the IEEE bus.
4. **Front Panel Calibration.** Temperature calibration may be performed from the front panel. Probe errors can be minimized with the calibration procedure.
5. **Four Wire Resistance Measurements.** Resistance measurements with the supplied probe are performed using the 4-wire method to minimize the effects of lead resistance.
6. **Selectable 3-wire or 4-wire Operation.** The instrument may be used with either 3-wire or 4-wire probes; the mode of operation is easily changed from the front panel.

### 1.3 WARRANTY INFORMATION

Warranty information may be found inside the front cover of this manual. Should it become necessary to use the warranty, contact your nearest Keithley representative or the factory to determine the correct course of action. Keithley Instruments, Inc. maintains service facilities in the United States, West Germany, Great Britain, France, the Netherlands, Switzerland and Austria. Information regarding the application, operation, or service of your instrument may be directed to the applications engineer at any of these locations. Check inside the front cover of this manual for addresses.

### 1.4 MANUAL ADDENDA

Information pertaining to improvements or changes to the in-

strument which occur after the printing of this manual will be found on an addendum sheet included with the unit. Be sure to note any changes before attempting to operate or service the instrument.

### 1.5 SAFETY TERMS AND SYMBOLS

The following safety terms are used in this manual or found on the instrument:

The  symbol on the instrument indicates that a potential of 1000V or more may be present on the terminal(s).

The  symbol on the instrument indicates that the user should refer to the operating instructions.

The **WARNING** heading used in this manual explains dangers that could result in personal injury or death.

The **CAUTION** heading used in this manual explains hazards that could damage the instrument.

### 1.6 SPECIFICATIONS

Detailed specifications pertaining to Model 195T temperature measurements are located at the front of this manual. All other specifications are located at the front of the Model 195 Instruction Manual.

### 1.7 UNPACKING AND INSPECTION

The Model 195T was carefully inspected before shipment. Upon receiving the unit, carefully unpack all items from the shipping carton and check for any obvious signs of physical damage. Report any damage to the shipping agent at once. Retain the original packing materials in case reshipment becomes necessary.

The following items are included with every Model 195T shipment:

- Model 195T System Temperature DMM
- Model 1951 Input Adapter Box
- Model 8693 General Purpose Immersion Probe (4-wire platinum RTD, DIN 43 760 standard)
- Model 195 Instruction Manual
- Model 195T Instruction Manual Supplement

### 1.8 SCOPE OF MODEL 195T INSTRUCTION MANUAL

This manual provides information pertaining to Model 195T temperature measuring capabilities and is supplied as a supplement to the Model 195 Instruction Manual, which contains information on all other operating aspects of the instrument. The Model 195T manual is divided into the following sections:

1. Section 2 contains information necessary to connect temperature probes and program the Model 195T to make temperature measurements. Additional IEEE bus commands are also included in this section.

2. Procedures necessary for checking temperature measuring accuracy are contained in Section 3.
3. Basic theory of operation may be found in Section 4.
4. Servicing information, including calibration, and a list of replaceable parts is located in Section 5.

## **1.9 ACCESSORIES**

Accessories available for the Model 195T are listed below. All probes are of 4-wire platinum RTD configuration and conform to the DIN 43 760 standard.

### **1.9.1 Model 1951 Input Adapter Box**

The Model 1951 (supplied with the Model 195T) provides a means of interfacing probes terminated with a 4-wire instrumentation connector to the banana jacks on the instrument.

### **1.9.2 Model 8691 Connector Kit**

The Model 8691 Connector Kit contains a male 4-wire connector, a female 4-wire connector with attached coiled cable (mates with connector on Model 1951), and male and female 3-wire adapters.

### **1.9.3 Model 8693 General Purpose Immersion Probe**

The Model 8693 (supplied with the Model 195T) is a general purpose probe designed for immersion in liquids as well as other general purpose applications. The Model 8693 measures between  $-220^{\circ}\text{C}$  and  $+630^{\circ}\text{C}$  and has a basic tolerance of  $\pm 0.3^{\circ}\text{C}$  at  $0^{\circ}\text{C}$ .

### **1.9.4 Model 8695 Surface Probe**

The Model 8695 probe is designed to measure the flat surfaces of solids in the range of  $-50^{\circ}\text{C}$  to  $+260^{\circ}\text{C}$ . The Model 8695 has a basic tolerance of  $\pm 0.3^{\circ}\text{C}$  at  $0^{\circ}\text{C}$ .

### **1.9.5 Model 8696 Air/Gas Probe**

The Model 8696 probe has an exposed junction within a protective shroud. The measurement range of the Model 8696 is between  $-50^{\circ}\text{C}$  and  $+260^{\circ}\text{C}$ ; the probe has a basic tolerance of  $\pm 0.3^{\circ}\text{C}$  at  $0^{\circ}\text{C}$ .



## SECTION 2 OPERATION

### 2.1 INTRODUCTION

This section contains information necessary to connect the temperature probe to the Model 195T and program the unit for temperature measurements. Also included is information on additional IEEE-488 bus commands and data formats.

### 2.2 PROBE CONNECTION

The Model 195T is supplied with the Model 1951 Input Adapter Box, designed to interface the unit with a standard 4-wire instrumentation connector. To connect the temperature probe to the instrument, proceed as follows:

#### WARNING

To avoid possible shock hazards, disconnect all test leads from the Model 195T before connecting the adapter box or temperature probe.

1. Connect the Model 1951 to the VOLTS OHMS and OHMS SENSE terminals on the front or rear panel of the Model 195T as desired. The input box is designed with suitable banana plugs designed to connect with the Model 195T banana jacks and includes a 4-wire connector, as shown in Figure 2-1. The box is designed to connect only one way.
2. Check to see that the rear panel INPUTS switch is in the correct position.
3. Connect the temperature probe to the jack on the front of the adapter. If desired, a probe may be wired using the connections shown in Figure 2-2.

#### NOTE

As shipped, the Model 195T is calibrated to use platinum probes conforming to the DIN 43 760 standard ( $\alpha = 0.00385$ ). Instrument calibration may be changed for other standards as described in Section 5.

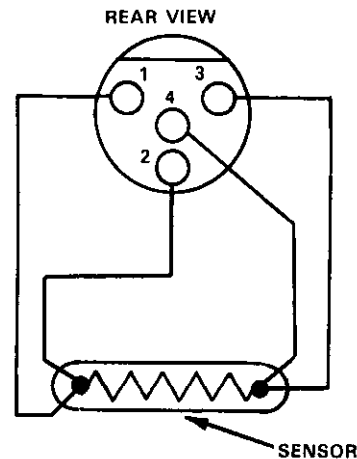

Figure 2-2. Model 195T Probe Wiring

### 2.3 TEMPERATURE MEASUREMENT PROCEDURE

Using the instrument to measure temperature is simply a matter of entering front panel Program 6, as described below.

1. Connect a suitable probe to the instrument as described in the last paragraph.

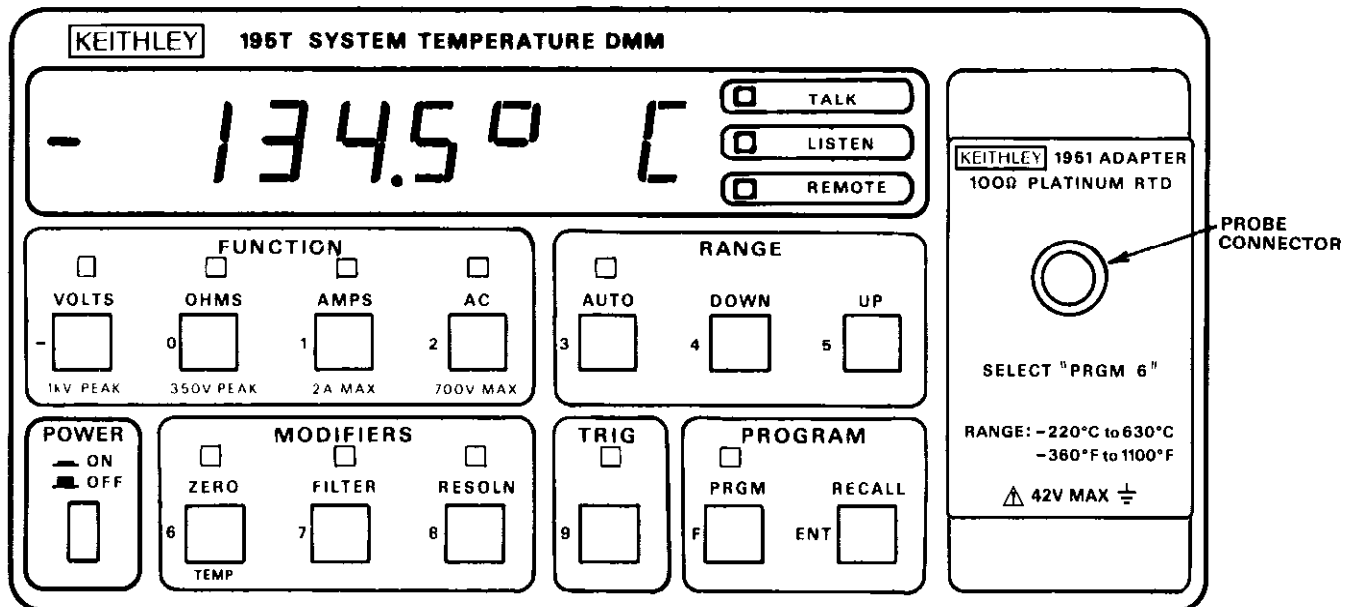

Figure 2-1. Model 195T Front Panel Showing Model 1951 Input Adapter Box

- Turn on the power to the instrument and allow it to warm up for at least one hour to achieve rated accuracy. Upon power-up, the instrument will display the programmed line frequency and software revision level similar to the example below.

F60t5

The Model 195T power-up message differs from the Model 195 message in that the "t" in the software revision level indicates the instrument is configured for temperature measurements.

- Press PRGM. The instrument will prompt for a program number as follows:

Pr o ?

- Press 6. The instrument will briefly display the program number as follows:

Pr o 6

- Following the program number, the unit will enter the temperature measuring mode; each time the PRGM, 6 key stroke sequence is performed, the instrument will toggle between the °C and °F temperature modes. The flashing decimal point shows the conversion rate.
- In the °C mode, a typical reading might be:

023.00 C

For a typical reading in the °F mode, the display might appear as follows:

074.00 F

- If the temperature is outside the measuring range of the instrument, or if the probe is open, the following message will be displayed:

OFLD

- Place the probe on or in the material to be measured and take the temperature reading. Allow sufficient time for the reading to stabilize.

#### WARNING

**Do not subject the temperature probe to a potential more than 30V RMS, 42.4V peak above earth ground, or a shock hazard may result.**

- To cancel the temperature mode, press a valid FUNCTION button, such as VOLTS.

#### NOTES:

- The instrument may be operated in either the 4½ digit or 5½ digit resolution mode while in the temperature mode. The RESOLN button on the front panel controls display resolution. When in the 5½ digit mode, the ° character is replaced by the least significant digit of the temperature reading.
- Temperature measurements may be stored in the internal buffer by entering Program 7 after entering the tempera-

ture mode. See Section 3 of the Model 195 Instruction Manual for front panel program details.

- The instrument may be placed in the one-shot mode when making temperature measurements by using Program 9. See Section 3 of the Model 195 Instruction Manual for details.
- As with other Model 195T measurements, the final, filtered temperature reading is not displayed until the FILTER light ceases flashing.
- Program 0 does not cancel the temperature mode.

### 2.4 IEEE BUS CONTROL OF TEMPERATURE MEASUREMENTS

The instrument may be placed in the temperature measuring mode with commands given over the IEEE bus, and temperature data may be read over the bus as described in the following paragraphs.

#### 2.4.1 IEEE Temperature Commands

The following commands control the Model 195T over the IEEE bus:

- F5 Places the instrument in the °F mode.
- F6 Places the instrument in the °C mode.
- S1 Default rate mode from front panel (rates must be programmed with appropriate rate commands).

#### NOTES:

- A DCL or SDC command transmitted over the bus to the instrument will cancel the temperature mode.
- As with other device-dependent commands, the instrument must be in the remote mode before it will respond to temperature commands. See Section 4 of the Model 195 Instruction Manual for complete details on using the unit over the IEEE-488 bus.

**Programming Example**—To program the instrument for temperature measurements in °C, enter the following statements into the HP-85:

```
REMOTE 716 (END LINE)
OUTPUT 716; "F6X" (END LINE)
```

When the END LINE is pressed the second time, the instrument will enter the °C temperature mode.

#### 2.4.2 IEEE Bus Temperature Data Format

Temperature data sent over the IEEE bus has a format similar to other instrument data. Formats for the two temperature modes are:

```
DEGFnnnn.nnE+n °F Mode
DEGCnnnn.nnE+n °C Mode
```

#### NOTES

- The data prefix is not present in the G1, G3 or G5 data modes.
- The bus reading rate may be increased by sending the following command string: S1P0X. However, noisier readings will result.

3. Turning the multiplex mode off with the A1 command will also increase the reading rate, but probe heating may increase, possibly affecting accuracy.

**Programming Example**—Connect a suitable probe to the instrument and enter the following statements into the HP-85 keyboard:

```

REMOTE 716 (END LINE)
OUTPUT 716; "F5X" (END LINE)
ENTER 716; A$ (END LINE)
DISP A$ (END LINE)
  
```

After the last statement is executed, the temperature data string will be displayed on the CRT.

### 2.5 3-WIRE SENSOR OPERATION

As supplied, the Model 195T is designed for operation with 4-wire probes, such as the supplied Model 8693 probe. However, the unit may be used with an appropriate 3-wire platinum RTD probe by using the connections shown in Figure 2-3. Before using a 3-wire probe, the instrument must be properly programmed as described in the calibration procedure in Section 5 of this manual.

#### WARNING

To avoid possible shock hazards, disconnect all test leads from the Model 195T before connecting the temperature probe.

#### NOTE

Model 195T temperature accuracy figures given in the specifications are based on 4-wire operation.

### 2.6 CALIBRATION STANDARDS

As shipped, the Model 195T is calibrated for use with probes conforming to the DIN 43 760 standard. Another popular temperature standard is the IPTS-68 standard, which uses

different calibration parameters, as summarized in Table 2-1. Note that it is imperative that the instrument be calibrated for the standard for which the probe is designed, or inaccurate temperature readings will result. Instrument calibration is covered in detail in paragraph 5.2.

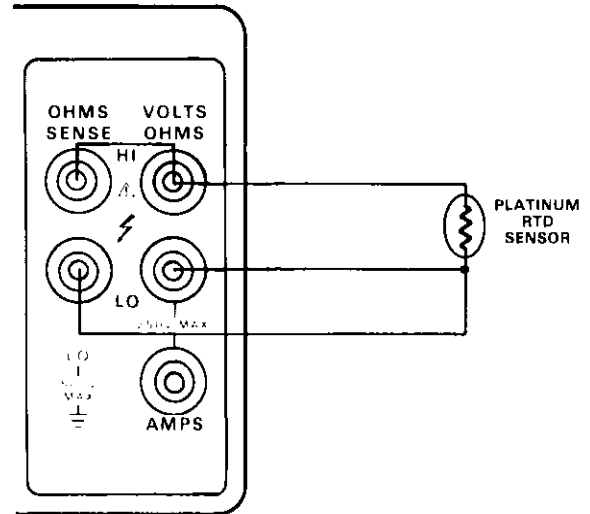

Figure 2-3. 3-Wire Sensor Connections

Table 2-1. Calibration Standards

Parameter	DIN 43 760 Standard	IPTS-68 Standard
$R_0$ (Probe resistance at 0°C)	100.00Ω	100.00Ω
Alpha	0.00385	0.00392
Delta	1.502	1.49633
A4, C4	*	*

\*Not directly programmable; automatically programmed by selection of DIN 43 760 or IPTS-68 standard during calibration.



## SECTION 3 PERFORMANCE VERIFICATION

### 3.1 INTRODUCTION

This section contains information necessary to verify that Model 195T temperature measurements are made within specified accuracy. Model 195T temperature specifications are located at the front of this manual. Performance verification may be performed when the instrument is first received to ensure that no damage or change in calibration has occurred during shipment. The verification procedure may also be performed following calibration. If performance is substandard, use the calibration procedure in Section 5 to bring the unit back within specifications. If that procedure does not bring the unit within specifications, complete calibration may be required; see Section 7 of the Model 195 Instruction Manual.

#### NOTE

If the instrument does not meet specifications, and it is still under warranty, (less than 12 months since the date of shipment) contact your Keithley representative or the factory to determine the correct course of action.

### 3.2 ENVIRONMENTAL CONDITIONS

Verification measurements should be made with the instrument at an ambient temperature between 18° and 28°C (65° to 82°F) at a relative humidity of less than 80%.

### 3.3 RECOMMENDED EQUIPMENT

The following equipment is recommended for performing the verification procedure:

Gen Rad precision decade resistance box Model 1433T, or equivalent ( $\pm 0.01\%$  tolerance). Other equipment may be used as long as the above accuracy figure is met or exceeded.

### 3.4 INITIAL CONDITIONS

Before performing the verification procedure, make sure the Model 195T meets the following conditions:

1. If the instrument has been subjected to temperatures below 18°C (65°F) or above 28°C (82°F), allow sufficient time for it to reach a temperature within this range. Typically, it takes one hour to stabilize an instrument 10°C (18°F) outside the normal range.
2. Turn on the power to the Model 195T and allow it to warm up for at least one hour before beginning the verification procedure.

### 3.5 VERIFICATION PROCEDURE

Model 195T temperature verification is based on substituting precise, known resistance values for the temperature probe

and seeing that the displayed reading falls within the required range.

#### NOTE

The following procedure assumes the instrument is calibrated for the DIN 43 760 standard ( $\alpha = 0.00385$ ). Other standards will require different resistor values. See Section 5 for information on calibration.

#### WARNING

**To avoid possible shock hazards, disconnect all other test leads from the unit before connecting the decade box.**

1. Connect the precision decade resistance box to the Model 195T as shown in Figure 3-1. Four wire connections must be used as shown on the diagram. Make sure the INPUTS switch is in the front panel position and that the instrument is programmed for 4-wire operation (paragraph 5.2.4).
2. Enter the °C temperature mode by pressing the PRGM and 6 buttons in sequence. If the display shows unit is in the °F mode, press PRGM and 6 in sequence again. Make sure the display is in the 5 ½ digit resolution mode; also see that ZERO is disabled.
3. Refer to Table 3-1, which summarizes the verification resistance values. To check Model 195T accuracy at each of the points, set the decade box to the indicated resistance value and see that the displayed Model 195T reading falls within the required range.

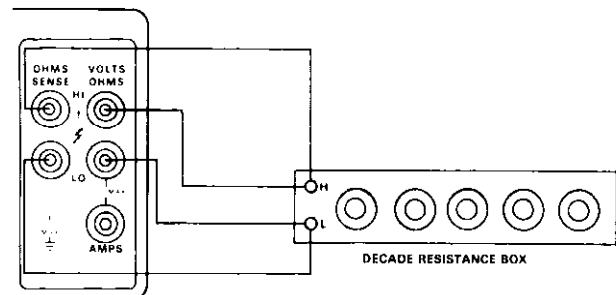

**Figure 3-1. Connections for Performance Verification**

**Table 3-1. Performance Verification Summary**

Nominal Temperature	Resistance Value	Allowable Reading (18° to 28°C)
-200°C	18.49Ω	-200.12 to -199.80°C
-100°C	60.25Ω	-100.13 to -99.87°C
0°C	100.00Ω	-0.10 to +0.10°C
+100°C	138.50Ω	+99.87 to +100.13°C
+200°C	175.84Ω	+199.84 to +200.16°C
+400°C	247.04Ω	+399.48 to +400.56°C
+600°C	313.59Ω	+599.42 to +600.58°C



## SECTION 4 THEORY OF OPERATION

### 4.1 INTRODUCTION

Model 195T temperature readings are based on the 4-wire resistance measurements of a platinum RTD (resistance temperature detector). As the probe temperature rises, its resistance increases as well, although not in a precisely linear manner.

In the Model 195T, these resistance measurements are made in the normal manner, but, during the measurement process, thermal voltages generated by dissimilar electrical contacts are cancelled out. This cancellation is achieved by making two measurements: the first is the voltage across the OHMS SENSE HI and LO terminals with current flowing through the RTD probe; the second measurement is made with no current flowing through the probe. These voltage measurements are then used by the microcomputer to calculate the temperature. Because the RTD current has a 25% duty cycle, probe heating is reduced; also, the off cycle allows thermal voltages to be measured.

### 4.2 RTD RESISTANCE MEASUREMENT

Figure 4-1 shows a simplified schematic of the Model 195T and RTD probe during temperature measurements.  $V_1$  through  $V_4$  represent thermal contact voltages generated by dissimilar metals.  $V_{RTD}$  is the voltage developed across the probe when current  $I$  is flowing. The remaining circuitry to the right is the normal Model 195 input and multiplexer circuitry.

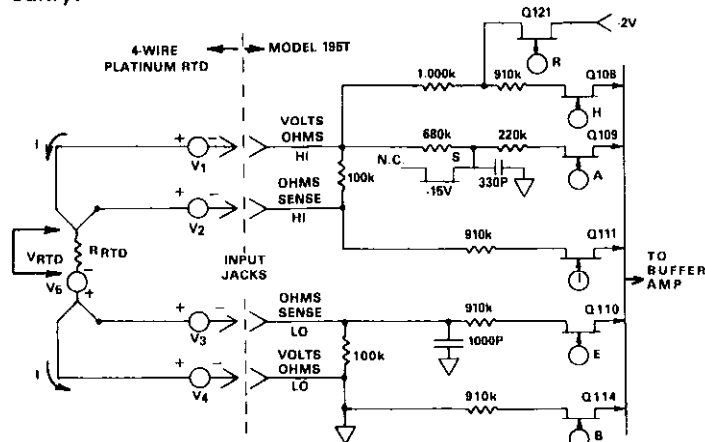

**Figure 4-1. Simplified Circuit of RTD Resistance Measurements**

When current is flowing through the RTD probe, the voltage, as seen at the OHMS SENSE HI and LO terminals, is:

$$V_{HI} - V_{LO} = V_2 + V_{RTD} + V_5 + V_3$$

With no current flowing, the voltage between these two terminals is:

$$V_{HI} - V_{LO} = V_2 + V_5 + V_3$$

Since the voltage is measured at the OHMS SENSE terminals,  $V_1$  and  $V_4$  are insignificant.

The resistance value of the probe can then be calculated as follows:

$$R_{RTD} = R_{ref} V_{RTD} / (V_{refHI} - V_{refLO})$$

### 4.3 FET SWITCHING SEQUENCE

As with all other Model 195T measurements, RTD resistance measurements are performed by switching various input FETs on and off. Figure 4-2 shows the general switching sequence for RTD measurements. Figure 4-3 shows the flow chart for the switching sequence. Each FET is assumed to be on when a positive pulse occurs.

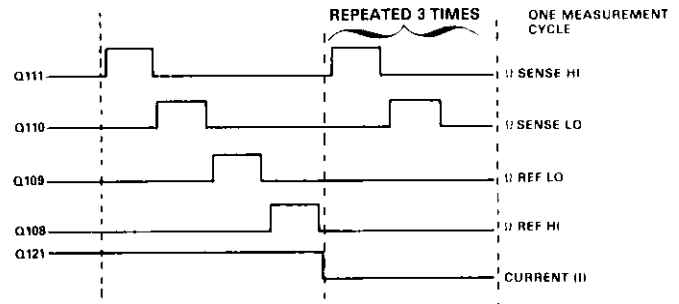

**Figure 4-2. FET Switching Sequence**

During the first phase of the measurement cycle, Q121 is turned on, causing current to flow through the RTD. Q111, Q110, Q109 and Q108 are then turned on in sequence to measure the voltage across the RTD with current flowing through it. During the second phase, Q121 is turned off, and Q111 and Q110 are turned on in sequence to perform the necessary measurements for the last phase. This last phase is repeated three times to provide the necessary duty cycle.

### 4.4 READING CALCULATIONS

Once the measurements are stored within the microcomputer, it is a simple matter to calculate the final reading. Above 0°C, these calculations are performed using the following relationships:

$$T_c = \frac{-A + \sqrt{A^2 - 4B[1 - R_t/R_0]}}{2B}$$

Where:

$$A = (1 + \alpha/100)$$

$$B = -\alpha\delta(10^{-4})$$

$\alpha$  and  $\delta$  are given constants

$R_0$  is the probe resistance at 0°C

$R_t$  is the probe resistance at the measured temperature

$$T_F = 9/5T_C + 32$$

**Example:**

Assume the Model 195T is used with a probe conforming to the DIN 43 760 standard and is measuring a temperature of 210°C. At this temperature with this probe, the values are:

$$R_0 = 100.00\Omega$$

$$R_t = 179.51\Omega$$

$$\alpha = 0.00385$$

$$\delta = 1.502$$

$$A = 0.00385[1 + (1.502/100)] = 0.0039078$$

$$B = -(10^{-4})(0.00385)(1.502) = -5.7827 \times 10^{-7}$$

$$T_c = \frac{0.0039078 + \sqrt{(0.0039078)^2 - 4(-5.7827 \times 10^{-7})[1 - (179.51/100)]}}{2(-5.7827 \times 10^{-7})}$$

$$T_c = 210^\circ\text{C}$$

$$T_F = (9/5)(210) + 32 = 410^\circ\text{F}$$

Below 0°C, two additional constants, A4 and C4, are used in a fourth order polynomial to calculate the temperature reading. These constants are not directly programmable, but their values will change in accordance with the selected standard (DIN 43 760 or IPTS-68), which can be programmed during the calibration procedure as described in paragraph 5.2.4.

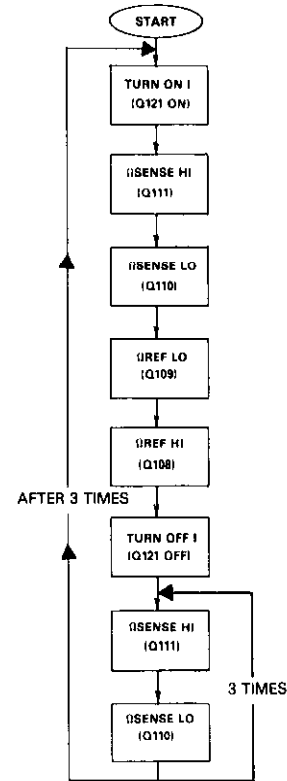

**Figure 4-3. FET Switching Sequence for RTD Resistance Measurements**



## SECTION 5 SERVICING INFORMATION

### 5.1 INTRODUCTION

This section contains temperature calibration procedures. Also included is a list of replaceable parts for the Model 195T.

### 5.2 CALIBRATION

Temperature calibration is performed by using front panel Program 5. The basic procedure is similar to that used for calibrating other instrument functions. The following paragraphs describe the basic calibration procedure.

#### NOTE

Proper temperature calibration requires that all other functions be properly calibrated (especially the 200 $\Omega$  and 2k $\Omega$  ranges). See paragraph 7.5 of the Model 195 Instruction Manual for those calibration procedures.

#### 5.2.1 Environmental Conditions

Calibration should be performed under laboratory conditions having an ambient temperature of 23  $\pm$  1°C and a relative humidity of less than 80%. If the instrument has been subjected to temperatures outside this range, or to higher humidity, allow at least one additional hour for operating conditions to stabilize.

#### 5.2.2 Warm-Up Period

Before beginning the calibration procedure, turn on the power to the Model 195T and allow the unit to warm up for at least one hour.

### 5.2.3 Calibration Constants

During the calibration procedure, the instrument will prompt for a number of constants. Table 5-1 summarizes prompt messages. Along with each prompting message, the display will show either the factory default value or the previously programmed value for each constant. The inputs required for calibration include:

1. Alpha—Used for reading calculations above 0°C (for DIN 43 760 standard, alpha=0.00385; for IPTS-68 standard, alpha=0.00392).
2. Delta—Also used for reading calculations above 0°C (for DIN 43 760, delta=1.502; for IPTS-68, delta=1.49633).
3. t=0°C—the probe resistance at 0°C.
4. DIN or NBS (IPTS-68) standard—Used to select appropriate A4 and C4 constants for better conformity below 0°C.
5. 3- or 4-terminal operating mode selection.

### 5.2.4 Front Panel Calibration Procedure

The Model 195T is factory calibrated to conform to the DIN 43 760 standard. The following calibration procedure may be used to change instrument calibration to another standard, or to optimize instrument performance for use with a specific probe. Proceed as follows:

#### NOTE

Program 0 may be used at any time during the calibration procedure to return the instrument to the normal mode. Simply press PRGM and 0 in sequence.

**Table 5-1. Calibration Procedure Messages**

Message	Purpose	Remarks
ALPHA	Prompts for alpha constant.	Default alpha value displayed after prompt (DIN 43 760=0.00385 IPTS-68=0.00392)
DELTA	Prompts for delta constant.	Default delta value displayed after prompt. (DIN 43 760=1.502 IPTS-68=1.49633)
t=0°C	Prompts for probe resistance at 0°C.	Default probe resistance value displayed after prompt.
n 5td 2	Prompts for DIN or NBS IPTS-68 standard.	Programmed standard displayed with prompt.
3or4t 4	Prompts for 3- or 4-wire probe operation.	Programmed operating mode displayed with prompt.
CAL	Shows temperature calibration in progress.	

1. Press PRGM. The instrument will prompt for a program number as follows:

Pro ?

2. Press 6. The instrument will briefly display the program number:

Pro 6

3. Following the program number, the unit will enter the temperature mode. To continue with calibration, press PRGM. The Model 195T will again prompt for a program number:

Pro ?

4. Press 5. The instrument will then display the program number followed by a prompt for the alpha parameter as follows:

ALPHA

5. Following the prompt, the default alpha value (for the DIN 43 760 standard) will be displayed:

.00385 + 0

6. If the displayed value of alpha is to be used, press ENT. If a new value of alpha is to be used, key in the digits and press ENT (the allowable range of alpha is  $0.00360 \leq \alpha \leq 0.00420$ ). For example, for the IPTS-68 standard, key in a value of 0.00392.

7. The unit will now prompt for the delta constant with the following message:

DELTA

8. After the prompt, the default value (for the DIN 43 760 standard) will be displayed:

150200 + 0

9. To use the displayed value, simply press ENT. To change the value, key in the digits and press ENT (the allowable range for delta is  $1.4 \leq \delta \leq 1.6$ ). For example, for the IPTS-68 standard, a value of 1.49633 would be used.

10. The instrument will now display a message prompting for the nominal probe resistance value at 0°C as follows:

t = 0°C

11. Following the prompt, the default probe resistance at 0°C (for the DIN 43 760 standard) will be displayed:

100.000 + 0

12. To use the present value, press ENT. To change the value, key in the digits and press ENT. Instrument performance is guaranteed for values between 85Ω and 120Ω, but the user may experiment with a wider range of values.

#### NOTE

If the precise probe resistance at 0°C is known, key in that value instead of the nominal value for better overall accuracy.

13. The unit will now prompt for operation on either the DIN or NBS (IPTS-68) standard. The importance of this selection lies in proper conformity for temperatures below 0°C. With the NBS standard, the display will appear as follows:

n Std ?

14. For the DIN standard, the display will show:

d Std ?

15. To select the DIN standard, press the 1 button. To select the NBS standard; press the 2 button. Once the desired standard is displayed, press ENT.

16. The instrument will now prompt for selection of 3-wire or 4-wire operation. For 4-wire operation, the display will appear as follows:

3 or 4t 4

17. Press 3 or 4 to select the desired mode, then press ENT. The unit will then display the following message to indicate that calibration is being performed.

CAL

After a few seconds, the unit will return to the normal temperature measurement mode.

#### NOTE

The following steps must be performed to permanently store temperature calibration constants in NVRAM.

18. Press PRGM. The instrument will prompt for a program number as follows:

Pro ?

19. Press 1. The instrument will briefly display the program number and then ask if NVRAM storage is desired:

Stor ?

20. Press ENT. If NV storage is successful, the instrument will return to normal operation after storing the temperature calibration values. Momentarily power down the unit before using the new calibration values.

#### NOTE

If the calibration jumper has been removed, NV storage will not be performed. Under these conditions, the following message will be displayed:

noStor

See Section 7 of the Model 195 Instruction Manual for calibration jumper details.

#### 5.2.5 Temperature Calibration Over the IEEE-488 Bus

The Model 195T temperature calibration sequence may be performed by sending commands over the IEEE bus with one of two methods.

1. Emulate the front panel control sequence with the H (hit button) command. (H10X, H5X, H0X, etc.)
2. Use the V command along with the calibration parameters after the instrument is in the temperature mode. For example, the following command string might be used:  
V0.00385X V1.49436X V100.00X V1X V4X

Note that it is not necessary to enter Program 5 before calibrating the instrument with the V command. See Section 4 of the Model 195 Instruction Manual for complete details on IEEE-488 bus programming.

**Programming Example:** Enter the following program into the HP-85 keyboard; be sure to press the END LINE key after each statement.

Program	Comments
10 REMOTE 716	Set up 195T for remote operation.
20 CLEAR 716	Return 195T to default conditions.
30 OUTPUT 716;"F6X"	Program for °C temperature mode.
40 OUTPUT 716;"V0.00392X"	Program alpha value.
50 OUTPUT 716;"V1.49633X"	Program delta value.
60 OUTPUT 716;"V101.00X"	Program probe resistance at 0°C.
70 OUTPUT 716;"V2X"	Program for NBS standard.
80 OUTPUT 716;"V3X"	Program for 3-wire operation.
90 END	

After entering the program, press the HP-85 RUN key. As each parameter is sent to the Model 195T, the value will appear on the display. Once all parameters have been programmed, the instrument will display the usual "CAL" message and then return to the normal temperature mode.

### 5.3 REPLACEABLE PARTS

The following paragraphs contain parts ordering information and a list of replaceable parts for the Model 195T.

#### 5.3.1 Ordering Information

Keithley Instruments, Inc. maintains a complete inventory of all normal replacement parts. To place an order, or to obtain information concerning replacement parts, contact your Keithley representative or the factory. When ordering parts, be sure to include the following information:

1. Instrument Model Number
2. Instrument Serial Number
3. Part Description
4. Circuit designation, including schematic and component layout numbers, if applicable.
5. Keithley Part Number

### 5.3.2 Parts List

Table 5-2 lists only those parts used by the Model 195T which are not used in the Model 195. For other Model 195 and Model 195T parts, refer to Section 8 of the Model 195 Instruction Manual.

**Table 5-2. Model 195T Replaceable Parts List**

Quantity	Description	Keithley Part Number
1	PROM (U112)	195T-800-XX*
1	Front Panel Overlay	195T-301
1	RTD Probe	8693-300
1	Box, Adapter	1951-301
1	Cover, Adapter Box	1951-302
1	Overlay, Adapter Box	1951-303
1	Connector, 4 Pin (Male)	CS-458
4	Banana Plug	BG-15-1
4	Terminal	TE-55
4	Standoff	ST-137-7

\*Order same last two digits as present software revision level.

### 5.4 TROUBLESHOOTING INFORMATION

The Model 195T differs from the Model 195 only in ROM configuration. In the Model 195, software is contained in two ROMs (one 8k and one 4k), U111 and U112. In the Model 195T, these two ROMs are replaced by a single 16k ROM (U112). Since this is the only difference between the two instruments, troubleshooting information located in the Model 195 Instruction Manual is also applicable to the Model 195T.

### 5.5 COMPONENT LAYOUTS AND SCHEMATICS

Component layouts and schematics for the Model 195T are located at the end of this section. Only those items associated with the Model 195T which differ from the Model 195 are contained in this supplement. For all other component layouts and schematics, refer to the Model 195 Instruction Manual.

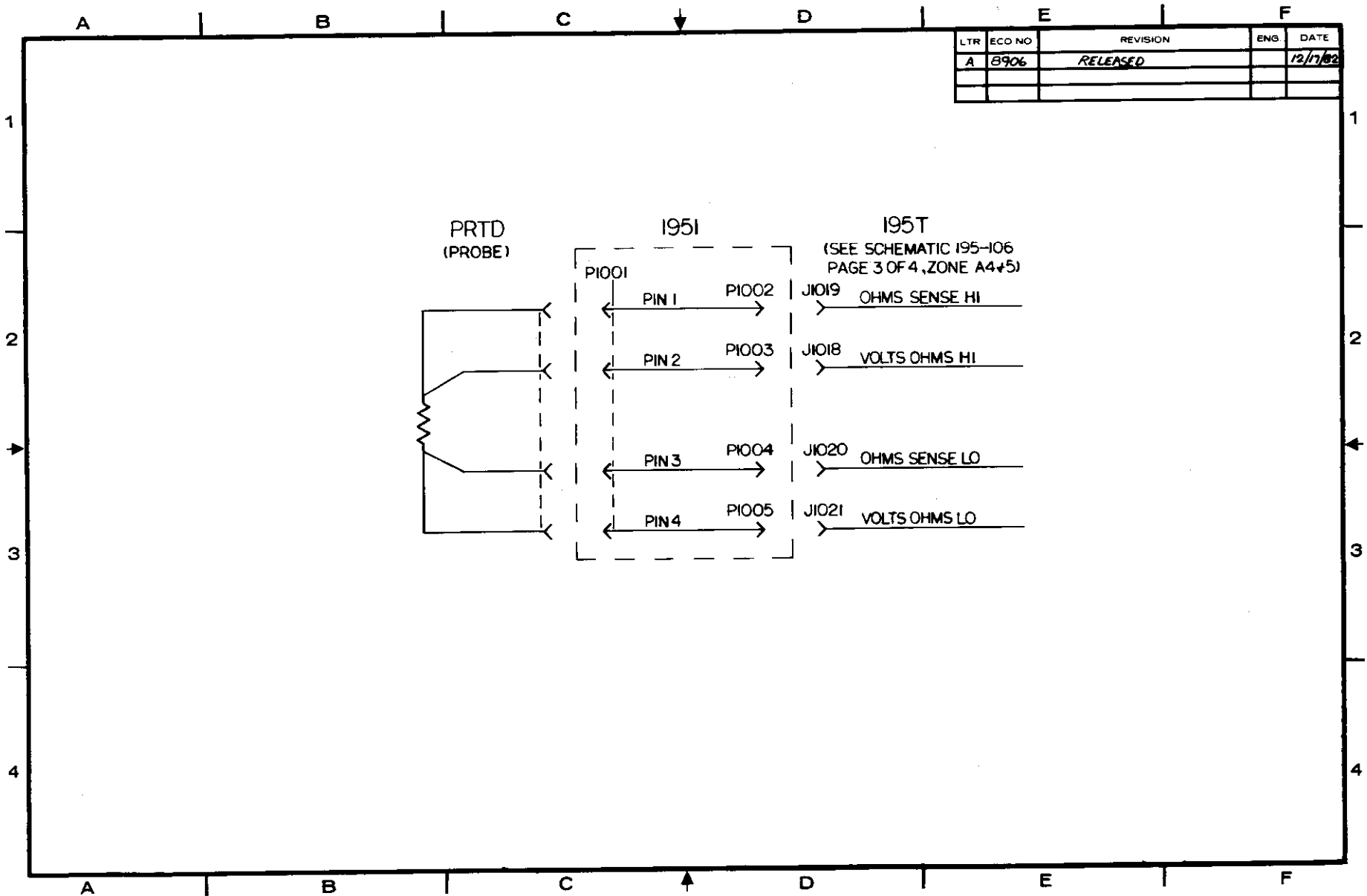
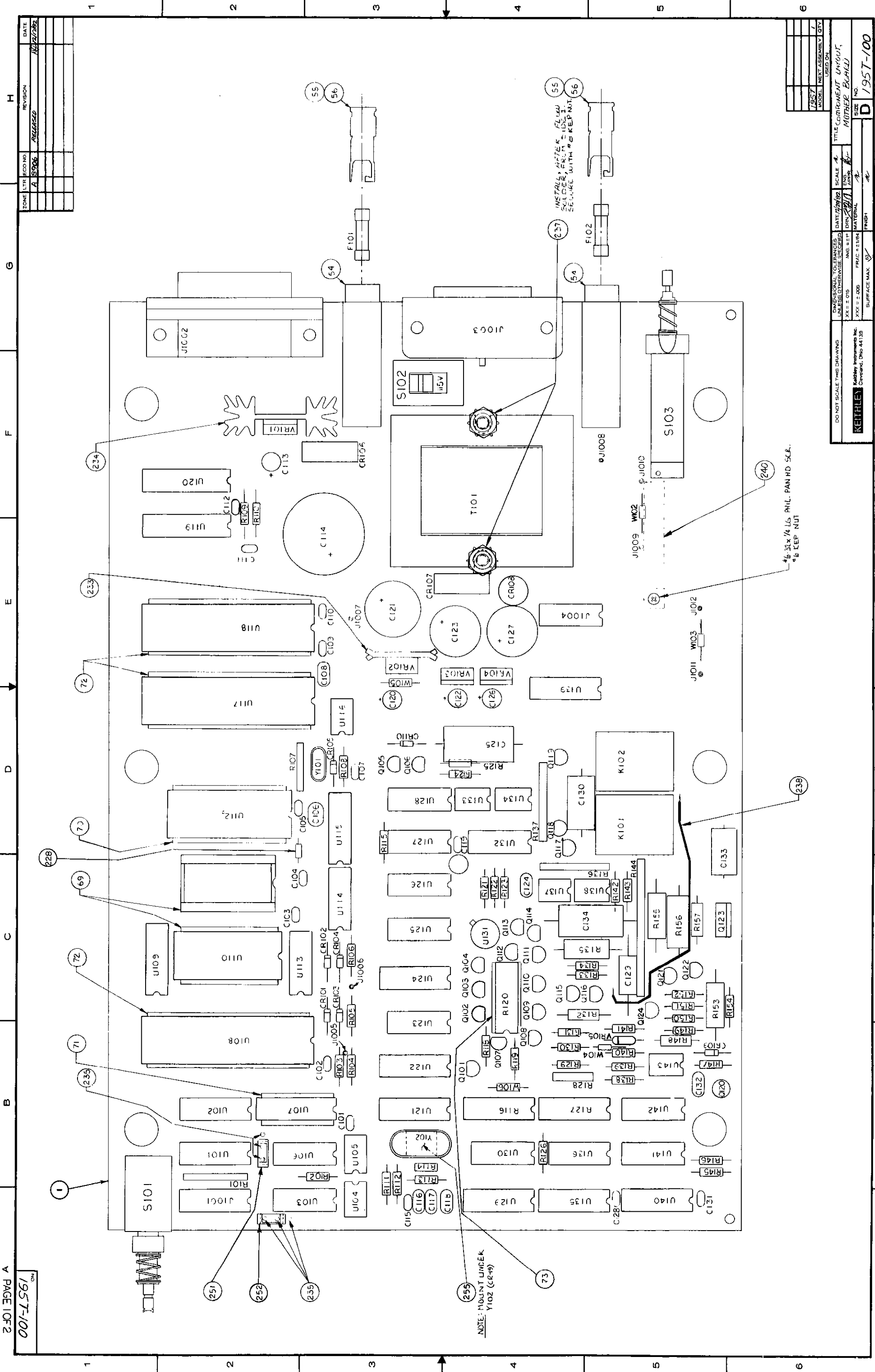

Figure 5-1. Remote Box, Schematic Diagram, Drawing Number 1951-106



195T-100  
PAGE 1 OF 2

REV.	DATE	REVISION
1	11/27/78	RELEASED
2		
3		
4		
5		
6		

DO NOT SCALE THIS DRAWING UNLESS OTHERWISE SPECIFIED		DIMENSIONAL TOLERANCES UNLESS OTHERWISE SPECIFIED		SCALE		TITLE	
XXX = ± .010	ANG ± .010	XXX = ± .005	PRAC ± .010	XXX = 1/16"	XXX = 1/32"	XXX = 1/64"	XXX = 1/128"
<b>KEITHLEY</b> Keithley Instruments Inc. Cleveland, Ohio 44130				DATE: 11/27/78 DESIGNED BY: [Signature] DRAWN BY: [Signature] CHECKED BY: [Signature] MATERIAL: [Blank] FINISH: [Blank]			
SURFACE MAX.				SIZE NO. <b>D</b> 195T-100			
MODEL: NEXT ASSEMBLY QTY.				USED ON:			

Figure 5-2. Mother Board, Component Layout, Drawing Number 195T-100 (Sheet 1 of 2)

195T-100

ZONE	LTR	ECO NO.	REVISION	DATE
A		6906	RELEASED	11/21/82

ITEM	PART NO.	SCHEM. DESIG.	ZONE
1	STAKING	195-101	
2			
3			
4	C-237-0.1	C101	B3
5	"	C102	B3
6	"	C103	C2
7	"	C104	C2
8	"	C105	D2
9	C-64-22p	C106	D3
10	C-237-1	C107	D3
11	C-64-22p	C108	E3
12	C-237-0.1	C109	E3
13	"	C110	E3
14	"	C111	E2
15	"	C112	F2
16	C-314-10	C113	F2
17	C-342-10000	C114	E3
18	C-237-0.1	C115	A3
19	C-22-6800p	C116	A3
20	C-22-150p	C117	A3
21	C-22-33p	C118	A4
22	C-237-0.1	C119	C4
23	C-314-10	C120	D3
24	C-314-2200	C121	E3
25	C-314-10	C122	D3
26	C-309-620	C123	E3
27	C-22-33p	C124	C4
28	C-138-3600	C125	D4
29	C-314-10	C126	D4
30	C-307-620	C127	E4
31	C-237-0.1	C128	A5
32	C-138-330	C129	C5
33	C-138-1500	C130	D4
34	C-237-0.1	C131	A5
35	C-64-150p	C132	E5
36	C-138-1000	C133	C5
37	C-138-3600p	C134	C5
38			
39			
40			

ITEM	PART NO.	SCHEM. DESIG.	ZONE
41			
42			
43	RF-28	CR101	C3
44	"	CR102	C3
45	"	CR103	C3
46	"	CR104	C3
47	"	CR105	D3
48	RF-48	CR106	F3
49	"	CR107	E3
50	RF-46	CR108	E4
51	RF-38	CR109	B5
52	RF-28	CR110	D3
53			
54	FH-21	2REQ'D	63,65
55	FH-25	2REQ'D	63,65
56	FH-28	2REQ'D	63,65
57	SO-65	J1001	A2
58	CS-443	J1002	C2
59	CS-388	J1003	C4
60	SO-70	J1004	E4
61	24249A	J1005	B3
62	"	J1006	C3
63	"	J1007	E3
64	"	J1008	F5
65	"	J1009	E3
66	"	J1010	F5
67	"	J1011	D3
68	"	J1012	E5
69	SO-68	2REQ'D	D1
70	SO-69	1REQ'D	D1
71	SO-82	1REQ'D	E1
72	SO-84	3REQ'D	C, D, E1
73	SO-65	1REQ'D	C4
74			
75	RL-72	K101	D5
76	"	K102	D5
77			
78	CR-10	Y101	D3
79	CR-19	Y102	B3
80			

ITEM	PART NO.	SCHEM. DESIG.	ZONE
81	TG-47	Q101	B4
82	TG-139	Q102	B4
83	"	Q103	C4
84	"	Q104	C4
85	TG-84	Q105	D3
86	"	Q106	D3
87	TG-139	Q107	B4
88	"	Q108	B4
89	"	Q109	C4
90	"	Q110	C4
91	"	Q111	C4
92	"	Q112	C4
93	"	Q113	C4
94	"	Q114	C4
95	31841	Q115	C4
96	TG-128	Q116	C5
97	"	Q117	C4
98	"	Q118	D4
99	"	Q119	D4
100	TG-39	Q120	B5
101	31841	Q121	C5
102	"	Q122	C5
103	TG-137	Q123	C5
104	TG-139	Q124	C5
105			
106			
107			
108	TF-100	R101	B2
109	R-76-220	R102	B3
110	R-76-10K	R103	B3
111	R-76-330	R104	B3
112	R-76-100	R105	C3
113	"	R106	C3
114	TF-101	R107	D2
115	R-76-1M	R108	D3
116	R-246-249	R109	F2
117	R-246-750	R110	F2
118	R-76-220	R111	B3
119	R-76-330	R112	B3
120	R-76-15M	R113	E3

ITEM	PART NO.	SCHEM. DESIG.	ZONE
121	R-76-2.2K	R114	E3
122	R-76-10K	R115	D3
123	TF-108	R116	B4
124			
125	R-282-910K	R118	B4
126	"	R119	B4
127	TF-146	R120	C4
128	R-76-100K	R121	C4
129	R-76-1K	R122	C4
130	R-88-11K	R123	C4
131	R-88-1M	R124	D3
132	R-88-6.34K	R125	D4
133	R-76-1M	R126	B4
134	TF-108	R127	B4
135	TF-150	R128	B4
136	R-282-910K	R129	B4
137	"	R130	B4
138	"	R131	B4
139	R-1-220K	R132	C5
140	R-282-820K	R133	C5
141	R-282-910K	R134	C5
142	R-2-910K	R135	C5
143	TF-149	R136	D5
144	TF-85	R137	D4
145	R-76-7.5K	R138	B5
146	R-88-6.19K	R139	B5
147	R-88-1.54K	R140	B5
148	R-88-10.7K	R141	B5
149	R-88-7.5K	R142	C5
150	R-88-12.7K	R143	C5
151	TF-148	R144	C5
152	R-76-10K	R145	E5
153	"	R146	E5
154	R-76-3.3K	R147	B5
155	R-1-220K	R148	B5
156	R-76-1M	R149	B5
157	"	R150	C5
158	"	R151	C5
159	"	R152	C5
160	R-2-100K	R153	C5

ITEM	PART NO.	SCHEM. DESIG.	ZONE
161	R-76-10K	R154	C5
162	R-3-690K	R155	C5
163	R-315-1.05K	R156	C5
164	R-263-100K	R157	C5
165			
166			
167			
168			
169	SW-422	S101	B1
170	SW-425	S102	F3
171	SW-443	S103	F5
172			
173			
174	TR-194	T101*	F4
175	TR-196	T101	F4
176			
177	IC-250	U101	B2
178	"	U102	B2
179	IC-179	U103	A2
180	IC-292	U104	A3
181	"	U105	E3
182	IC-144	U106	E2
183	LSI-50	U107	B2
184	LSI-28	U108	B2
185	IC-190	U109	C2
186	LSI-51	U110	C2
187			
188	LSI-800-XX	U112	D2
189	IC-186	U113	C3
190	IC-163	U114	C3
191	IC-280	U115	C3
192	IC-71	U116	D3
193	LSI-27	U117	D2
194	LSI-49	U118	E2
195	IC-298	U119	E2
196	IC-299	U120	F2
197	IC-106	U121	E3
198	IC-197	U122	E3
199	IC-138	U123	B3
200	IC-324	U124	C3

ITEM	PART NO.	SCHEM. DESIG.	ZONE
201	IC-103	U125	C3
202	IC-179	U126	C3
203	IC-216	U127	D3
204	29198	U128	D3
205	IC-251	U129	A4
206	IC-219	U130	B4
207	30167	U131	C4
208	29198	U132	D4
209	IC-179	U133	D4
210	IC-176	U134	D4
211	IC-135	U135	A4
212	IC-219	U136	B4
213	IC-42	U137	C4
214	IC-246	U138	C5
215	IC-206	U139	E4
216	IC-251	U140	A5
217	IC-219	U141	B5
218	"	U142	B5
219	IC-246	U143	B5
220			
221			
222			
223	IC-317	VR101	F2
224	IC-93	VR102	E3
225	IC-194	VR103	E4
226	IC-195	VR104	E4
227	DF-58	VR105	B5
228	J-3	D3	D3
229	"	W102	F5
230	"	W103	E5
231	"	W104	E5
232	"	U105	F5
233	HS-21	E3	E3
234	HS-25	F2	F2
235	24249A	6 REQ'D	~
236			
237	FA-147	2 REQ'D	E, F4
238	SC-55		D6
239			
240	26533A	REQ'D	F6

ITEM	PART NO.	SCHEM. DESIG.	ZONE
241	FU-29	F101*	G3
242	FU-32	F101	G3
243	FU-40	F101†	G3
244	FU-31	F101	G3
245	FU-13	F102*	G5
246	FU-46	F102	G5
247			
248			
249			
250	J-3	W106	B4
251	CS-447	W107	B2
252	"	W108	A2
253			
254			
255	27493-26	1 REQ'D	A4
256			
257			
258			
259			
260			
261			
262			
263			
264			
265			
266			
267			
268			
269			
270			
271			
272			
273			
274			
275			
276			
277			
278			
279			
280			

\* FOR U.S. 115V. OPERATION.  
 † FOR U.S. 230V. OPERATION.

DO NOT SCALE THIS DRAWING	DIMENSIONAL TOLERANCES UNLESS OTHERWISE SPECIFIED	DATE 3-22-82	SCALE 1:1	TITLE COMPONENT LAYOUT
KEITHLEY Keithley Instruments Inc. Cleveland, Ohio 44139	XXX = .005 SURFACE MAX	DRN 23	ENG APPR	MOTHER BOARD
				SIZE D
				NO 195T-100

Figure 5-2. Mother Board, Component Layout, Drawing Number 195T-100 (Sheet 2 of 2)

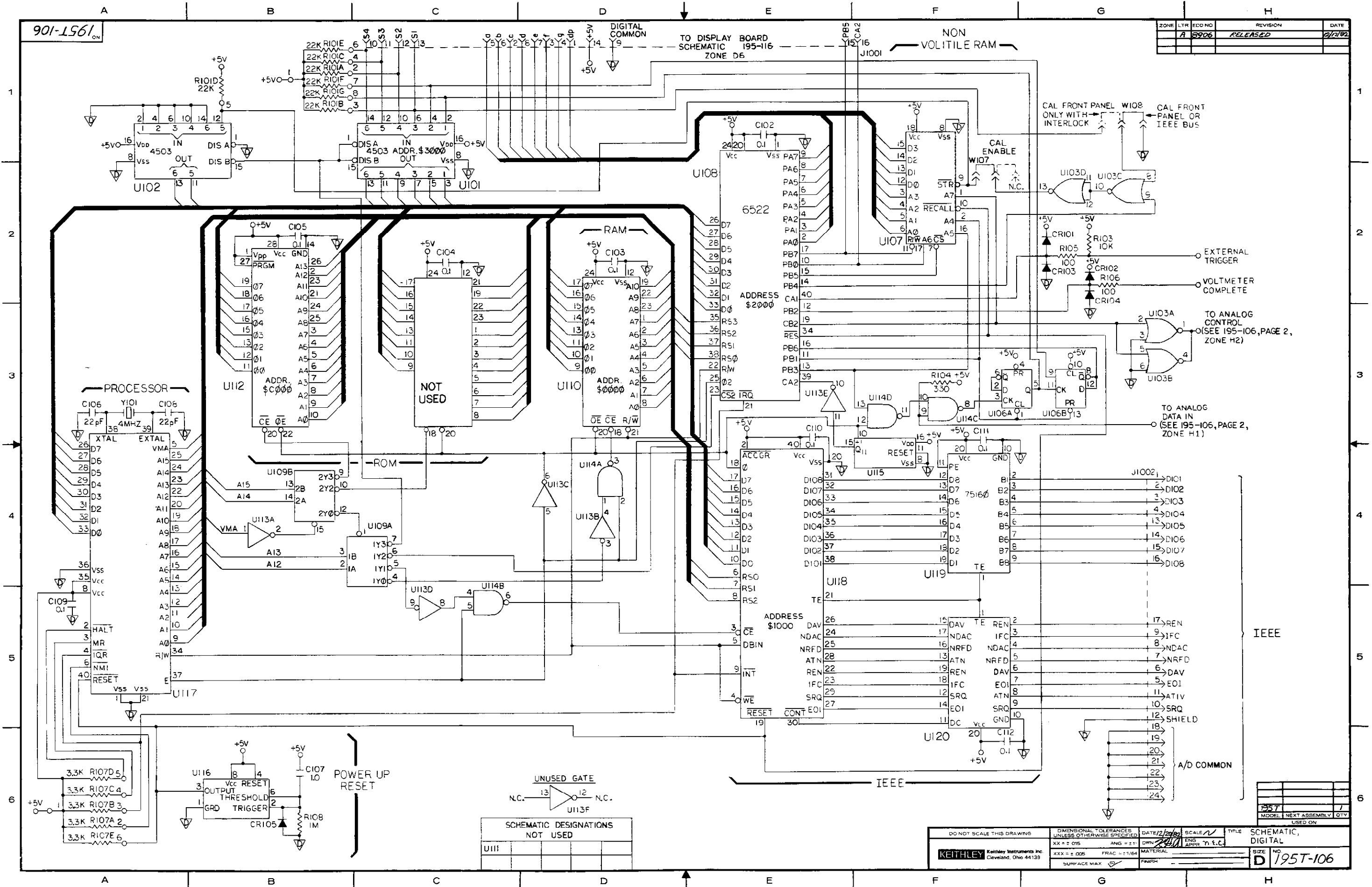

Figure 5-3. Mother Board, Schematic Diagram, Drawing Number 195T-106





# KEITHLEY

**Keithley Instruments, Inc./28775 Aurora Road/Cleveland, Ohio 44139/U.S.A./(216) 248-0400/Telex: 98-5469**

**WEST GERMANY: Keithley Instruments GmbH/Heighofstrasse 5/D-8000 München 70/(089) 714-40-65/Telex: 521 21 60**

**GREAT BRITAIN: Keithley Instruments, Ltd./1, Boulton Road/Reading, Berkshire RG2 ONL/(0734) 86 12 87/Telex: 847047**

**FRANCE: Keithley Instruments SARL/2 Bis, Rue Léon Blum/B.P. 60/91121 Palaiseau Cedex/(6) 011.51.55/Telex: 600933F**

**NETHERLANDS: Keithley Instruments BV/Arkelsedijk 4/NL-4206 AC Gorinchem/(01830) 25577/Telex: 24 684**

**SWITZERLAND: Keithley Instruments SA/Kriesbachstr. 4/CH-8600 Dübendorf/01 821 94 44/Telex: 57 536**

**AUSTRIA: Keithley Instruments Ges.m.b.H./Döblinger Hauptstr. 32/A-1190 Wien/0222 314 289/Telex: 13 45 00**